

Series 5800 Pump

Model: 58XX-7X01-B714
 Flow Range: Open Flow = .82-1.40 GPM
 At 70 PSI = .48-.95 GPM

COMPLETING THE PART NUMBER:

58XX-7X01-B714

Steel Mounting Plate (Other Types Available)

Desired Shut-off Pressure & Code

A = 30PSI C = 45PSI E = 60PSI

B = 40PSI D = 50PSI F = 70PSI

70 PSI Pressure Switch Limit (Maximum Flow Components)

Select Pumphead Model From Performance Data Chart

3 = Open Ports for 3/8" Compression Fitting

5 = Push-to-Connect Ports for 3/8" Tubing

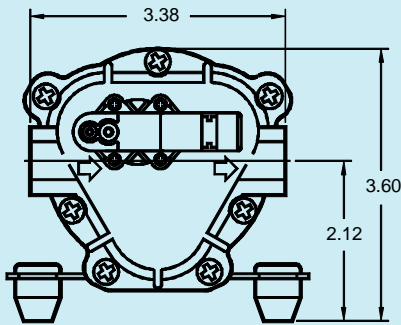

SPECIFICATIONS:

■ MOTOR:

TYPE:

230 VAC, 50/60 HZ, Permanent Magnet, Totally Enclosed, Non-Ventilated

LEADS:

14 AWG, 12" LONG

TEMP. LIMITS:

For User Safety, Optimal Performance, and Maximum Motor Life, This Motor is Equipped with a Thermal Protector that Limits the Motor Shell Temperature to 145°F (63°C), as Shown on the Heat Rise Graph.

DUTY CYCLE:

See Heat Rise Graph

■ PUMP DESIGN:

3 Chamber Diaphragm Pump, Self Priming, Capable of Being Run Dry

■ TYPICAL APPLICATION:

Industrial Grade Water Transfer

■ MATERIALS:

HOUSINGS:

Nylon

VALVES:

EPDM

DIAPHRAGM:

Santoprene

FASTENERS:

Stainless Steel

■ LIQUID TEMPERATURE:

170°F (77°C) Max.

■ PUMP CERTIFICATIONS:

NSF Standard 58

■ PRIMING CAPABILITIES:

	58X0	58X1	58X2	58X3	58X4
PRIME (FEET)	5	5.5	6	9	9.5

■ FITTINGS:

TYPE	SHAPE	KIT NO.	CONNECTS TO...
3/8" COMPRESSION	STRAIGHT	25-145	3/8" TUBING
3/8" COMPRESSION	ELBOW	25-146	3/8" TUBING
3/8" STEM	STRAIGHT	25-144	3/8" JOHN GUEST PUSH-ON FITTING

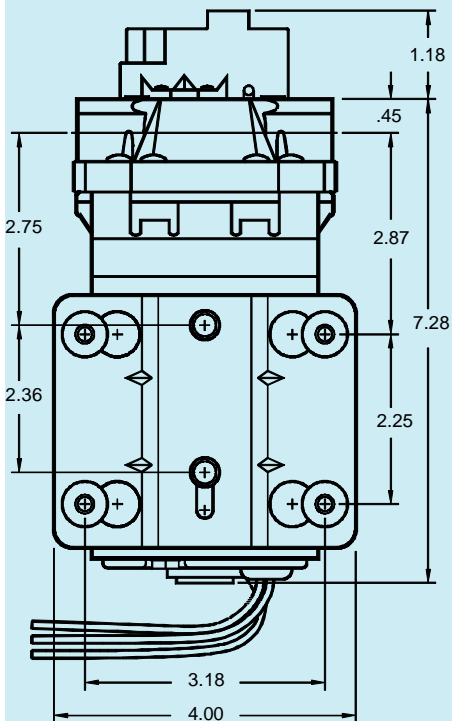

WEIGHT: 6 lbs.



Aquatec International, Inc.
 17422 Pullman Street, Irvine, CA 92614
 Sales: 949-225-2200 Fax: 949-225-2222
 www.aquatec.com

Series 5800 Pump

Model: 58XX-7X01-B714

PERFORMANCE DATA										
DISCHARGE	PUMPHEAD MODEL									
PRESSURE	58X0		58X1		58X2		58X3		58X4	
(PSI)	FLOW (GPM)	CURRENT (AMPS)	FLOW (GPM)	CURRENT (AMPS)	FLOW (GPM)	CURRENT (AMPS)	FLOW (GPM)	CURRENT (AMPS)	FLOW (GPM)	CURRENT (AMPS)
70	0.48	0.19	0.58	0.22	0.82	0.27	0.90	0.32	0.95	0.34
60	0.52	0.18	0.64	0.21	0.88	0.25	0.95	0.29	1.00	0.33
50	0.56	0.16	0.70	0.19	0.92	0.23	0.98	0.27	1.08	0.29
40	0.65	0.15	0.75	0.17	0.95	0.21	1.05	0.24	1.15	0.26
30	0.68	0.14	0.80	0.15	0.96	0.19	1.10	0.21	1.22	0.22
20	0.75	0.12	0.85	0.13	0.97	0.18	1.15	0.19	1.28	0.20
10	0.80	0.11	0.91	0.11	1.05	0.17	1.25	0.17	1.35	0.19
OPEN	0.82	0.10	0.93	0.10	1.17	0.14	1.28	0.16	1.40	0.18

PERFORMANCE MEASURED WITH FLOODED INLET (0 PSI), 70°F (21°C) AMBIENT AND WATER TEMPERATURE, AND VOLTAGE CONTROLLED AT 230 VAC, 60 HZ. POSITIVE INLET PRESSURE WILL INCREASE THE DISCHARGE PRESSURE BY A SIMILAR AMOUNT, FOR A GIVEN FLOW. MAXIMUM INLET PRESSURE IS 60 PSI.

SHADED AREA DENOTES CONTINUOUS OPERATION CAPABILITY AT DESIGNATED PRESSURE AND CURRENT.

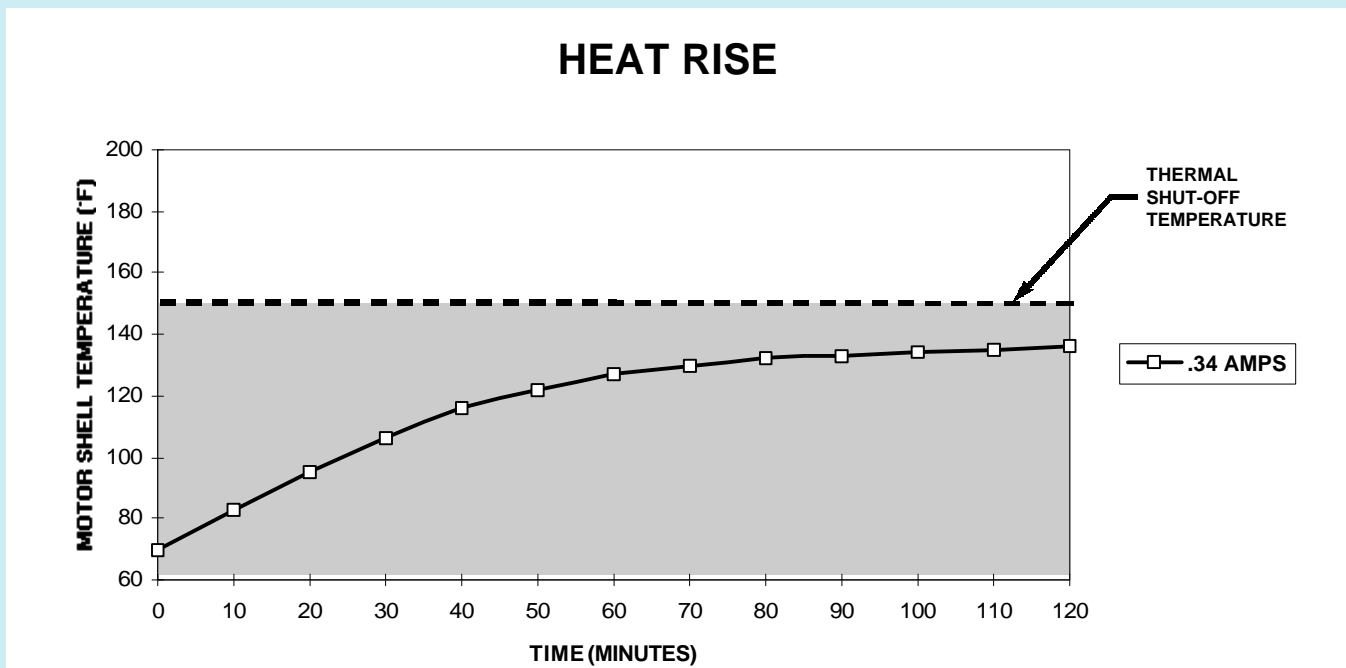

All of the pump models in the Performance Data and Heat Rise charts are in the shaded area, meaning they are capable of sustaining continual running, at any of the above listed pressures, without shutting down to allow the motor to cool. To conserve wearing parts, however, the pump should only operate as needed.

ALL PERFORMANCE AND HEAT RISE FIGURES ARE APPROXIMATE. ACTUAL VALUES WILL VARY WITH AMBIENT CONDITIONS.